

FILED FOR RECORD 3-30- 1981 at 1:00 o'clock P M
DULY RECORDED 3-31- 1981 at 9:00 o'clock A M
INSTRUMENT NO. _____ GRACE BOSTICK, TYLER CO. CLK.

Grace Bostick

TYLER COUNTY COMMISSIONER'S COURT
SPECIAL MEETING
MARCH 13, 1981

00L.6 Pg. 345

A Special Meeting of the Commissioner's Court, met on Friday, March 13, 1981 at 10:00 A.M. All members being present. The meeting was opened with prayer by County Judge Allen Sturrock.

Mr. Joe Weeks gave a presentation of his Recordings.

A motion was made by Commissioner Lowe and seconded by Commissioner Odom to accept the highest Bid, for the car, from the Sheriff's Dept., from L.E. (Buddy) Greenwood, for the price of \$525.00. All voted yes and none no. See Bids attached.

A motion was made by Commissioner Riley and seconded by Commissioner Odom to place, "Folger" the Drug Dog, on the Tyler County Sheriff's Inventory, at the value of \$4500.00. It will be permissible for this dog, with a trainer from Tyler County, to be used in other counties. If the dog is killed, then this value fee is paid to Tyler County. The fee for using the dog will be decided by the Sheriff. All voted yes and none no. As to where the dog will be located or who will have charge of him will be decided later.

A motion was made by Commissioner Lowe and seconded by Commissioner Odom to give J.P. Judge John Spanhanks, the authority to have the Courthouse exterminated for Roaches, on a one-time basis. Judge Spanhanks said that he believed this would be the best way to rid the roaches. All voted yes and none no.

A motion was made by Commissioner Mahan and seconded by Commissioner Riley to accept the Bid of Bill West, Rt. 1 Box 548, Jasper, Texas, on the chainlink fence for Pct. #III, County Barn. The accepted bid was \$5800.00. Two bids were presented. All voted yes and none no. See Bids attached. This cost will be paid for, from Revenue-sharing fund.

A motion was made by Commissioner Mahan and seconded by Commissioner Riley to reject any and all Bids on the Tilt Trailer for Pct. #III. All voted yes and none no. See Bids attached.

A motion was made by Commissioner Mahan and seconded by Commissioner Lowe to table the consideration of County Atty. Joe Smith, on a six man Jury Box for County Court. All voted yes and none no.

A motion was made by Commissioner Riley and seconded by Commissioner Odom to approve of paying bills for the County, as submitted by the County Auditor, Ann Fondren. All voted yes and none no. See attached.

A motion was made by Commissioner Mahan and seconded by Commissioner Riley to accept a Budget Revision, for the District Attorneys Office. All voted yes and none no. See attached amendment.

The Commissioners discussed a resolution, asking the legislature to raise the salary that can be payed to Juvenile Judges. It was decided, by Commissioner Riley making the motion which was seconded by Commissioner Mahan, not to send the Resolution. All voted yes and none no.

A motion was made by Commissioner Riley and seconded by Commissioner Lowe to table the discussion from Don Cole. All voted yes and none no.

There being no further business, the meeting adjourned.

SIGNED: Allen Sturrock Allen Sturrock, County Judge

Maxie Riley Maxie Riley, Comm. Pct. #1

H.K. Lowe H.K. Lowe, Comm. Pct. #2

Jerry Mahan Jerry Mahan, Comm. Pct. #3

Berton Adnell Odom Berton Adnell Odom, Comm. Pct. #4

ATTEST: Grace Bostick Grace Bostick, County Clerk

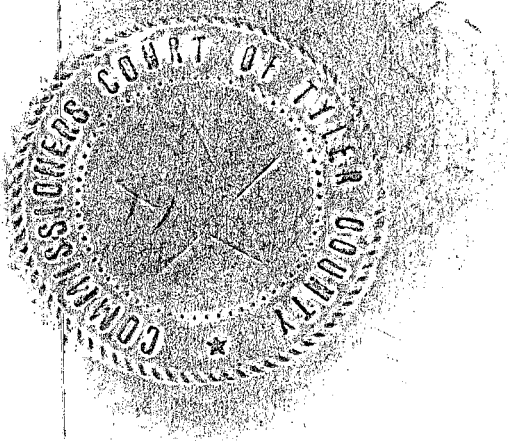

3/9/81

002. 6 Pg. 347

I bid the following on
a 1977 Blue Ford Car
belonging to the Tyler County
Sheriff's Dept. in the amount of
\$525⁰⁰

Respectfully submitted
L. G. (Buddy) Greenwood
Woodville, Texas

001-6 18.348

77 B100

Ford

T195. Car

NOV 29 1981

NO. _____ TIME: 9:05 AM

GRACE BOSTICK, COUNTY CLERK
TYLER COUNTY, TEXAS

BY: ~~Mrs. Bostick~~

Paul

Shirley Ann

VOL. 6

Pg. 349

JACK H. BURNS
RT. 1, BOX 928
WOODVILLE, TEXAS 75979

PHONE: 283-~~7237~~

I, JACK H. BURNS, SUBMIT A BID IN THE PROPOSED
AMOUNT OF \$ 417.00 (*Four Hundred Seventeen Dollars*)
FOR THE FOLLOWING:

1- 1977 FORD LTD

(4 door PASSENGER CAR)

(COLOR, *Blue*)

THE AFORE MENTIONED VEHICLE BEING PROPERTY OF
TYLER COUNTY TEXAS.

SINCERELY,

Jack H. Burns
JACK H. BURNS

00L.6

pg. 350

NO. _____ TIME: 8:00 PM

MAY 03 1981

Comm. Court of Tyler Co.

Bid for Sale of Sheriff Dept. Auto.

GRACE BOSTICK, COUNTY CLERK
TYLER COUNTY, TEXAS

BY: *Carrie Campbell*

To: Tyler County

Subject: Chain Link fencing at Pct. 111
County barn.

All work to be done according to specs.
and material to meet specs.

The companies that I buy material
tell me they do not furnish a written
guarantee - but that it should last at
least 30 years.

If contract is awarded to me I should
be able to finish job in 8 to 10 days. The
weather permitting.

My Bid is \$5800⁰⁰

Bill West
Rt. 1 Box 548
Jasper, Texas, 75951
Phone | 384-2367

Bice West

Rt. 1 Box 548
Jasper, Texas, 75951
Phone 384-2367

{Bid on Fencing}

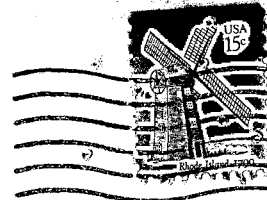

NO. _____ TIME: 10:00 AM
PM

MAR 03 1981

GRACE BOSTICK, COUNTY CLERK
TYLER COUNTY, TEXAS

BY: *Katrina Hooks*
Katrina Hooks

Office of County Clerk
County of Tyler,
Court House,
Woodville,
Texas,

NO. _____ TIME: _____ AM
PM

MAR

GRACE BOSTICK, COUNTY CLERK
TYLER COUNTY, TEXAS

BY: _____

OPEN BY MISTAKE

Vol. 6
Pg. 352

J & J FENCE CO.

1190 MAGNOLIA TE 2-1512

BEAUMONT, TEXAS

00L.6

pg. 353

DATE 3-9-81

SOURCE OF LEAD _____

TELEPHONE NUMBER _____

JOB LOG NO. _____

PROPOSAL TO County BARN

ADDRESS _____ Zone _____

LOCATION Colmesweil Pct IV

SPECIFICATIONS: All work will be performed in a workmanlike manner and in accordance with standard practice. All posts set in concrete.

Total Height <u>7'</u>			Check Caption Preferred	KEY	Additional Specifications															
Post Spaced <u>10'</u>	Top Rail <input checked="" type="checkbox"/> <u>1 3/8"</u> O.D.		<table border="1"> <tr> <td>Fence to be erected</td> <td><input type="checkbox"/></td> </tr> <tr> <td>Tie-ons (Get permission)</td> <td>X</td> </tr> <tr> <td>Terminal post</td> <td><input type="checkbox"/></td> </tr> <tr> <td>Existing fence</td> <td>X X X X X</td> </tr> <tr> <td>Walk gate</td> <td><input type="checkbox"/></td> </tr> <tr> <td>Double gate</td> <td><input type="checkbox"/></td> </tr> <tr> <td colspan="2">Clothes post location must be shown on plan.</td> </tr> <tr> <td colspan="2">Indicate if sides are shared.</td> </tr> </table>	Fence to be erected	<input type="checkbox"/>	Tie-ons (Get permission)	X	Terminal post	<input type="checkbox"/>	Existing fence	X X X X X	Walk gate	<input type="checkbox"/>	Double gate	<input type="checkbox"/>	Clothes post location must be shown on plan.		Indicate if sides are shared.		Top Rail _____ O.D.
Fence to be erected	<input type="checkbox"/>																			
Tie-ons (Get permission)	X																			
Terminal post	<input type="checkbox"/>																			
Existing fence	X X X X X																			
Walk gate	<input type="checkbox"/>																			
Double gate	<input type="checkbox"/>																			
Clothes post location must be shown on plan.																				
Indicate if sides are shared.																				
Style Fence <u>C.L.</u>	Line Post <input type="checkbox"/> <u>1 3/8"</u> O.D.		Line Post <u>1 7/8</u> O.D.																	
Gauge <input type="checkbox"/> 9 <input checked="" type="checkbox"/> 11	End Post <input checked="" type="checkbox"/> <u>2 1/2"</u> O.D.		End Post _____ O.D.																	
Knuckled <input type="checkbox"/>	Corner Post <input checked="" type="checkbox"/> <u>2 1/2"</u> O.D.		Corner Post _____ O.D.																	
Safeguard <input type="checkbox"/> <u>X X X</u>	Walk Gate Post <input checked="" type="checkbox"/> <u>2 1/2"</u> O.D.		Walk Gate Post _____ O.D.																	
TERMS	Drive Gate Posts <input checked="" type="checkbox"/> <u>2 1/2"</u> O.D.		Drive Gate Posts <u>1 5/8</u> O.D.																	
Cash Upon Completion <input type="checkbox"/>	Gate Frames <input type="checkbox"/> <u>1 3/8"</u> O.D.		Gate Frames _____ O.D.																	
F.H.A. <input type="checkbox"/>																				

Gate Ornaments: Dogs Scrolls Terminal Post Ornaments: Horseheads Name Scroll

Top Rail of Fence to Follow Ground
 Be Level With Lowest Grade
 Be Level With Highest Grade

QUANTITY	DESCRIPTION	PRICE	TOTAL
1264	C.L. Fence	\$5.056	00
8	T.P.	200	00
4	Gates	350	00
2	Gate Post	70	00

Total \$5576.00
 Sales Tax _____
 Down _____
 TOTAL _____

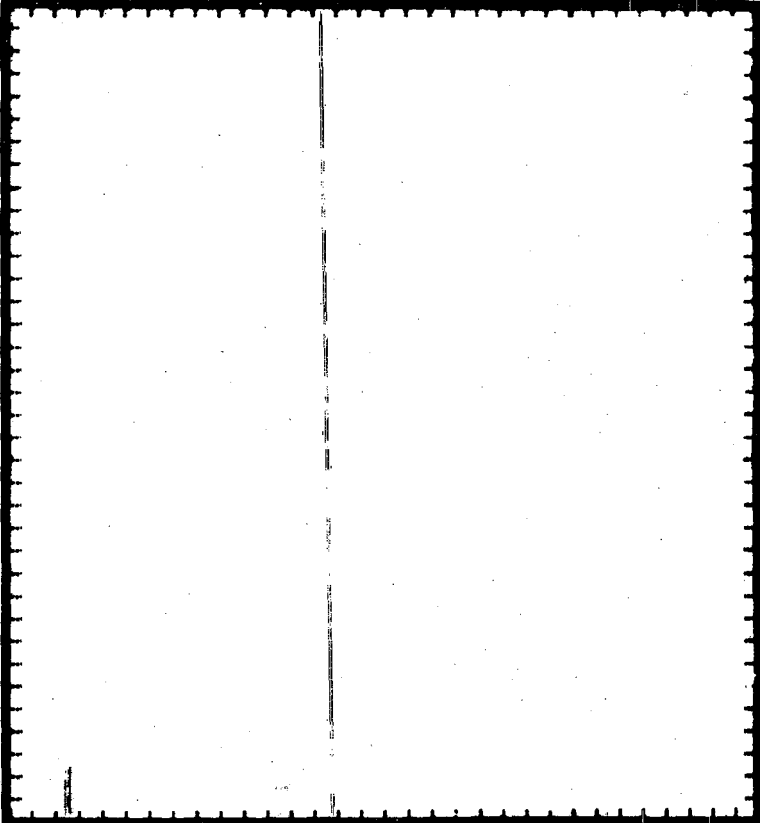

MORE OR LESS MATERIAL OTHER THAN AMOUNT CONTRACTED FOR WILL BE DEBITED OR CREDITED AT CURRENT RATES
 NOTICE: If contract is changed after the erection crew delivers the material or if undue delay is caused the company, there will be a \$7.50 per hour charge for all time lost.
 You, as the PROPERTY OWNER ARE SOLELY RESPONSIBLE FOR LOCATING PROPERTY LINE.
 NO CONDITIONS, AGREEMENTS or STIPULATIONS, VERBAL or OTHERWISE, save those mentioned above shall be recognized.

Salesman _____
 Sales Manager _____
 Accepted for _____
 Credit Department _____

ACCEPTED _____

J & J Fence Co.

1190 MAGNOLIA
BEAUMONT, TEXAS 77701

Rt 3 ⁴ Box 1535
Woodville Tex
75979

[Handwritten signature]

Jerry Mahan
County Burn
Colmesneil Pct. III

NO. _____ TIMES 9:05 ^{AIR} PM

MAR 09 1981

GRACE BOSTICK, COUNTY CLERK
TYLER COUNTY, TEXAS
BY: *[Signature]*
KIRBY HOOKS

0476 P. 3574



VOL. 6 Pg. 355

CONFIRMATION-SPECIAL QUOTE/BID

DATE: 3/2/81

DUE DATE: 3/9/81

DEALER: GENERAL ENGINES

NO. of UNITS: 1

ARLINGTON TX

QUOTE FOR: PRIVATE CUSTOMER

817-467-1221

GOVERNMENT BODY TYLER Co.

ATTENTION: _____

BID NO. _____

MODEL/OPTIONS

PRICE

20 TXT - F.O.B. ARLINGTON, TX.

12,284.03

TERMS: PRICE GOOD 30 DAYS

DELIVERY: 30 DAYS

If paid within 10 days and if FET exemption certificate is supplied your net delivered cost would be: _____

EXCEPTIONS/NOTES: 24 FOOT BED LENGTH



Manufacturers of:
Trailers • Ramps
Rollers • Pavers

DAVID A. CARR
Regional Sales Manager

SOUTHWEST PLANT
1100 Interstate 20 West
Arlington, Texas 76017
(817) 467-1221

General Engines Co., Inc.
Route 130, Thorofare, N.J. 08086
(609) 845-5400



GENERAL ENGINES CO., INC., 1100 Interstate 20 West, Arlington, Texas 76017

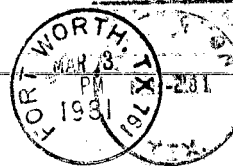

1227033

NO. _____ TIME: 10:15 AM
PM

MAR 05 1981

ATTN: COUNTY CLERK

GRACE BOSTICK, COUNTY CLERK
TYLER COUNTY, TEXAS

BY: [Signature]

TYLER COUNTY COURT HOUSE

P.O. Box 100

Woodville, Texas 75979

100-10
19.356

SUPERTRAILERS PAVERS ROLLERS RAMPS



Allen Machinery Company, Inc.

P.O. Box 3327 - Loop 287 West
Lufkin, Texas 75901
Phone 713-634-8801

March 4, 1981

UOL. 6 Pg. 357

Tyler County
Commissioner Court
Woodville, Texas

Gentlemen:

We are pleased to quote on the following Hercules trailer:

1-- 20 DBT (20 Ton) Tandem axle, dual wheel trailer with draw bar
hitch and 20 foot long bed. (Tilt trailer)

Net price FOB Job Site Equipped
with Air Brakes-----\$10,825.00

Net Price FOB Job Site Equipped
with Electric Brakes-----\$12,495.00

Note: For installation of hitch on dump truck and hooking up brakes,
please add \$200.00 to the above price.

Warranty: One Year

Delivery: 30 to 45 Days.

Yours very truly,

Glen McDaniel
Glen McDaniel
Sales

GM:JL

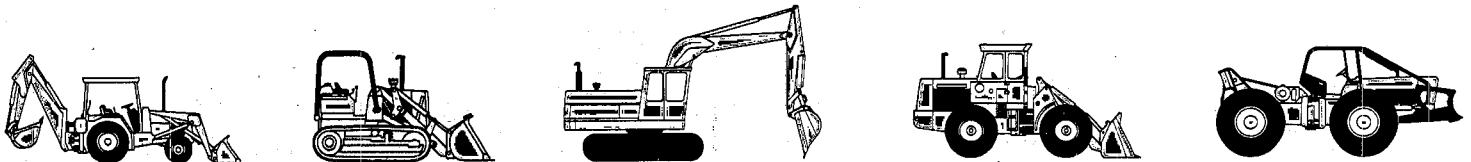



Allen Machinery Company, Inc.

P.O. Box 3327 - Loop 287 West
Lufkin, Texas 75901
Phone 713-634-8801

March 6, 1981

VOL. 6 Pg. 358

Tyler County
Woodville, Texas 75979

Dear Sir:

We are pleased to quote on the following alternate bid:

1 - 20 DBT (20) Tandem Axle, dual wheel trailer with draw bar hitch, with 24 foot long bed. (Tilt Trailer).

Net Price FOB Job Site

Equipped with air brakes-----\$11,325.00

Net Price FOB Job Site

Equipped with electric brakes-----\$12,995.00

Sincerely,

Glen McDaniel
Salesman

GM:JL

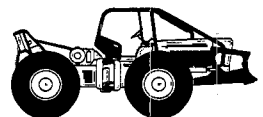
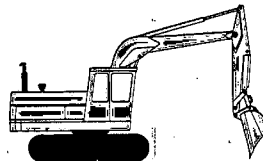
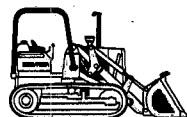
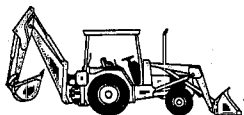

Eager Beaver

TILTS to give you an edge on competition

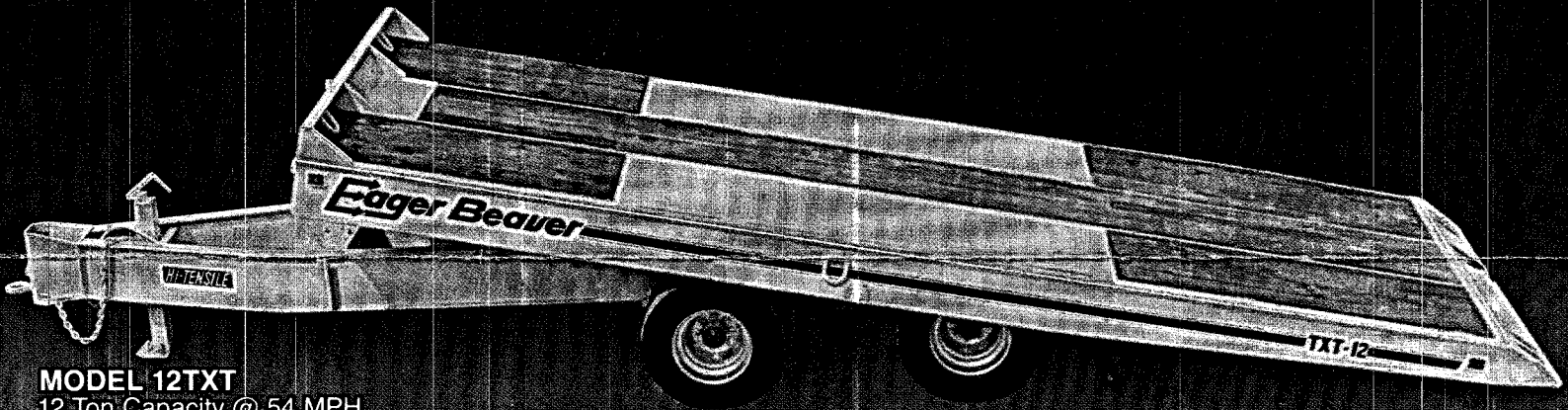

MODEL 12TXT
12 Ton Capacity @ 54 MPH

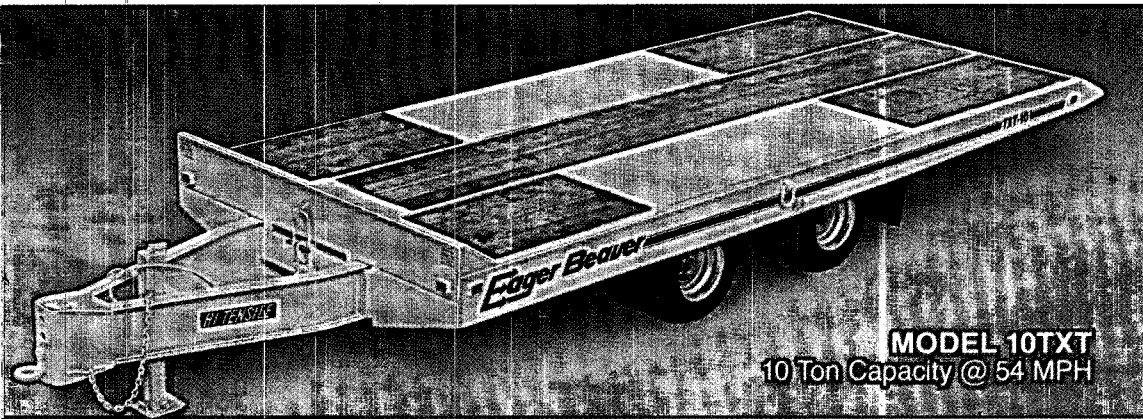

MODEL 10TXT
10 Ton Capacity @ 54 MPH

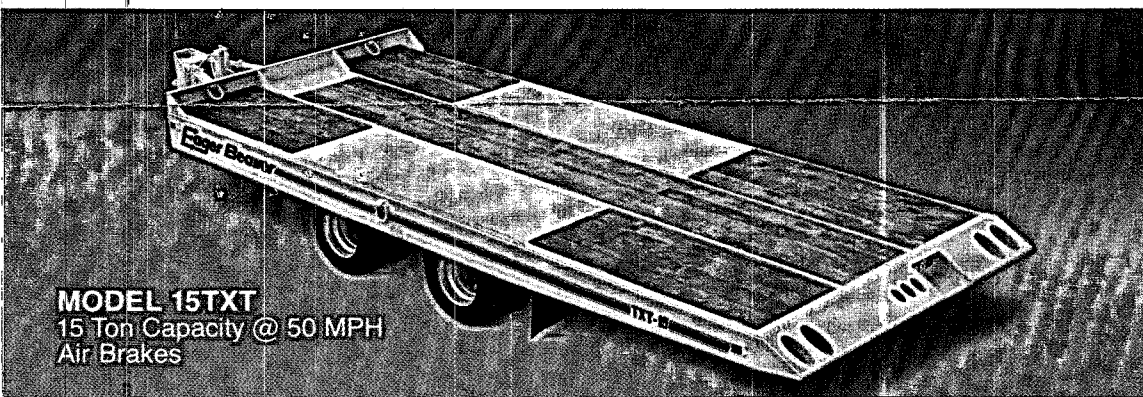

MODEL 15TXT
15 Ton Capacity @ 50 MPH
Air Brakes

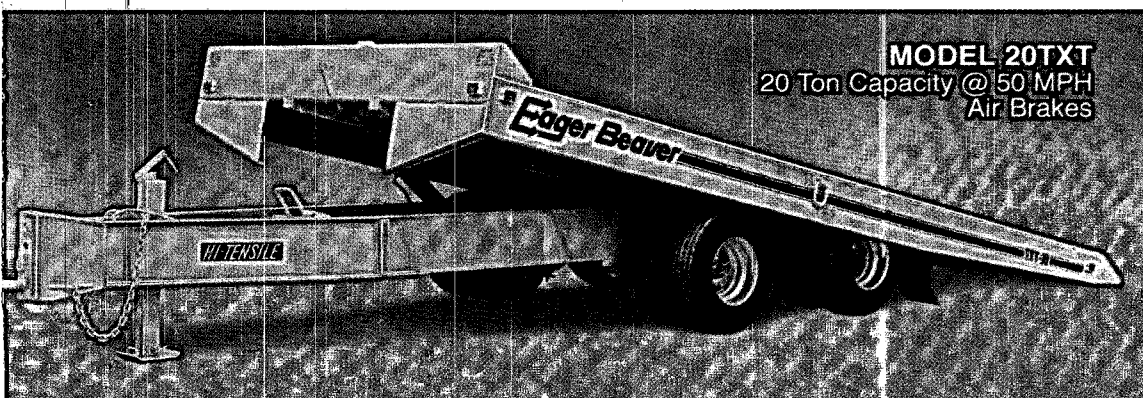

MODEL 20TXT
20 Ton Capacity @ 50 MPH
Air Brakes

Standard Features — all models

- Hydraulic Cushion Cylinder
- Tubular Upper Platform—Resists Twisting
- Adjustable Platform Lock
- Front Buckboard Stop
- Tapered Rear Deck
- Recessed Tail Lights
- Spring Suspension
- Bed Tilts with Weight of One Man
- 10,000 lb. Heavy Duty Parking Jack
- Winch Mount Plate
- 2 Inch Hardwood Decking
- Adjustable Hitch Plate
- Color—Safety Yellow
- Lights—Stop, Clearance, Running, Directional, License Plate
- Tie Down Rings—Two Each Side
- Electrical Junction Box with Circuit Breakers
- Safety Chains
- Mud Flaps
- Electric Brake Controller and Truck Wire Harness
- Lunette Eye

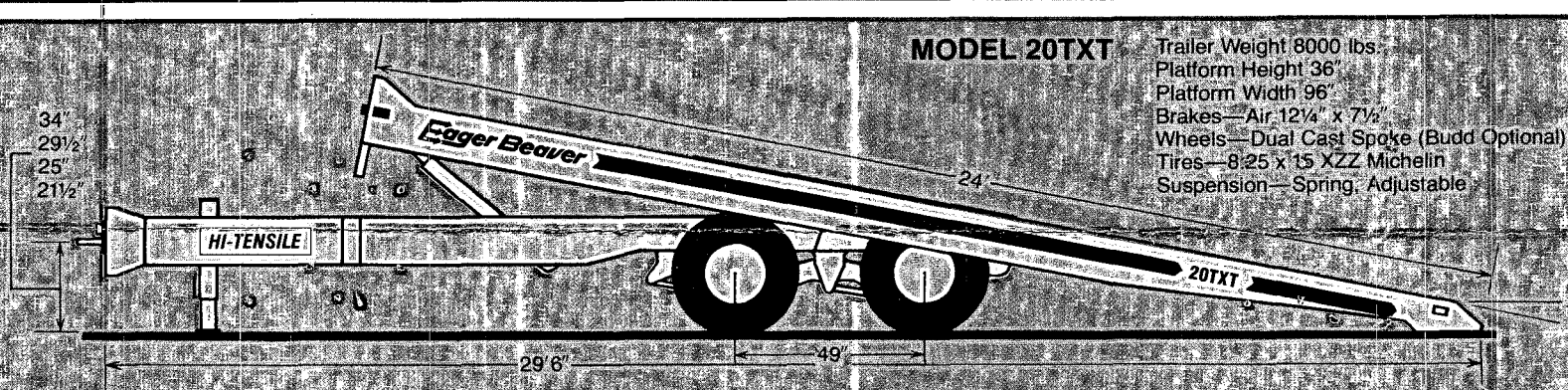
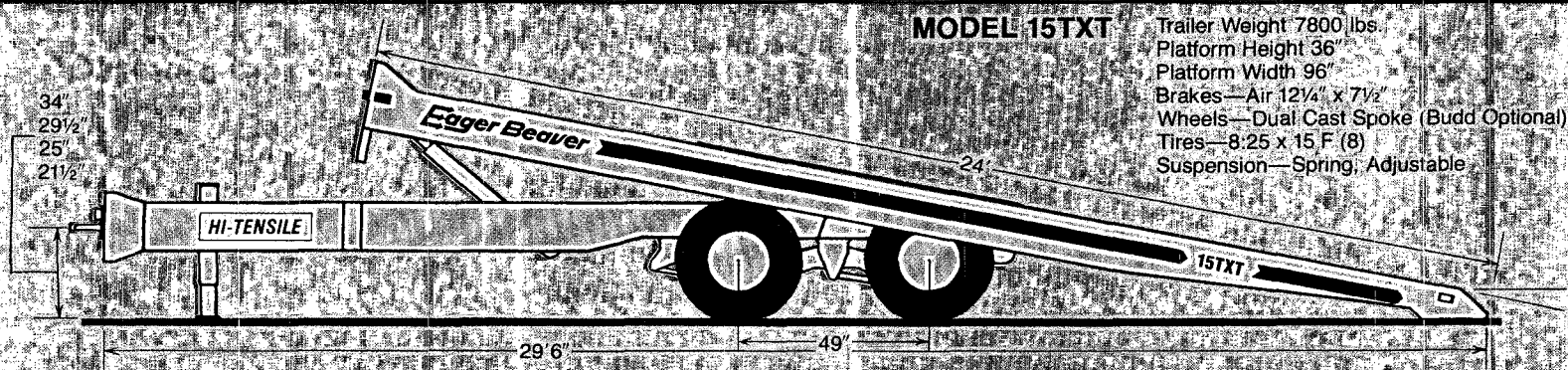
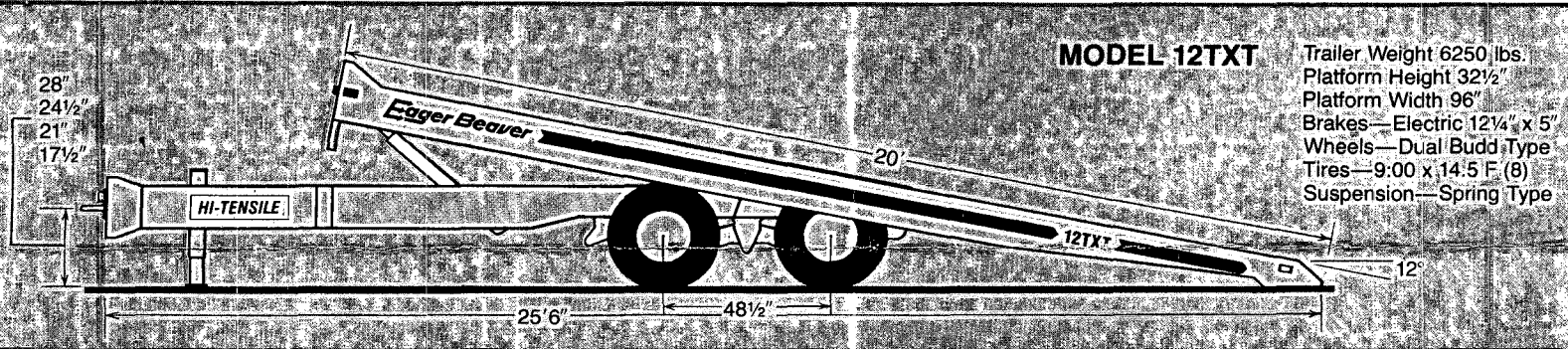
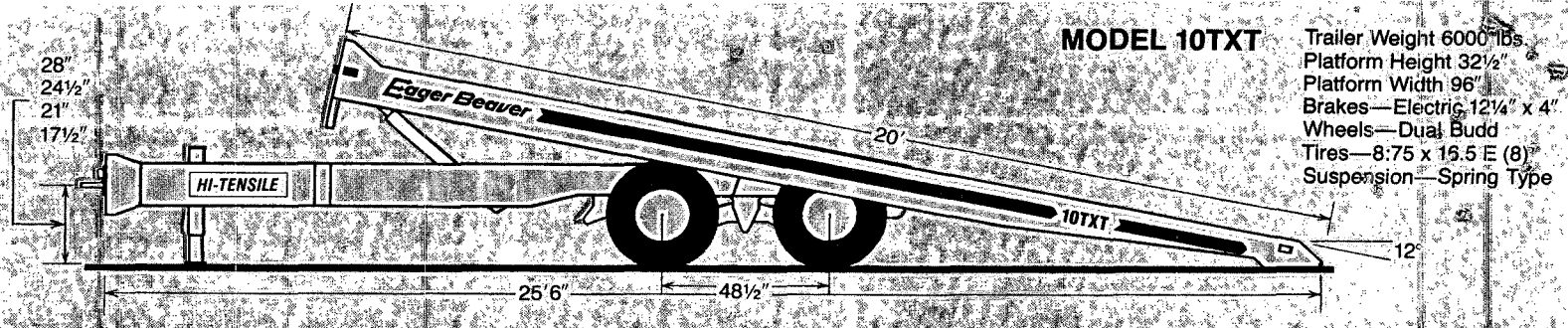

Eager Beaver®

Distributed by

1100 Interstate 20 West
 Arlington, Texas 76017
 Phone (817) 467-1221

Interstate 295
 Thorofare, New Jersey 08086
 Phone (609) 845-5400

ALLEN MACHINERY COMPANY, INC.

P. O. BOX 3327

LUFKIN, TEXAS 75901

VOL. 6 Pg. 359

COMMISSIONERS COURT

TYLER COUNTY

WOODYVILLE, TEXAS 75979

TRAILER BID

NO. _____ TIME: 9:45 ^{AM} _{PM}

MAR 09 1981

GRACE BOSTICK, COUNTY CLERK
TYLER COUNTY, TEXAS
BY: *Elaine Owen*

002.6 Pg. 360

COMMISSIONER'S COURT OF March, 19781

Page 1 of 3

CLAIM REGISTER AND MINUTES OF ACCOUNTS ALLOWED, General FUND TYLER COUNTY, TEXAS

Claim Number	NAME OF CLAIMANT	NATURE OF CLAIM	Amount of Claim	D All
16876	Brookshire Bros.	Food for Prisoners-Sheriff	\$ 38.81	
16822	Bobs Prescription Shop	Pictures-Sheriff Dept.	14.02	
16831	B&K Variety	Dist. Judge-.89 Office Supplies- Exten.-2.60	3.49	
16838	Clark, Jim, Atty.	County Court Appt'd Atty.-T.Jones 75.00, E. Garrett 75.00, V.M. Brown 75.00, J. F. Bonner 50.00	275.00	
16813	Allison Insurance Agency	Constable Bond-H. Crews	30.00	
16810	Collier Ins. Agency	Blanket Bond-Co. Clerk	97.00	
16830	C. J. Kirkland, Jr. Garage	Rep. Transmission-Ageing Dept.	16.50	
16836	City of Woodville	Utilities-Courthouse	822.61	
16837	C. J. Kirkland, Jr. Garage	Rep. to Mini-Bus	114.50	
16846	Consolidated Marketing, Inc.	Janitors Supplies	164.40	
16851	City of Woodville	Garbage Bags	11.25	
16865	Eastex Communications	Maint. Cont. March-181.00 Radio Installations-155.00	336.00	
16825	Exxon Co.	Gas-Sheriff	255.23	
16818	Gulf States Utilities	Courthouse Sheriff Tarver-Utilities 497.68	519.35	
16819	Gulf Oil Corporation	Gas-Sheriff	199.23	
16871	Hansen, Ann	Recording Directory-Co. Clerk	9.95	
16870	Hart Graphics	Fee Books-Co. Clerk	6.78	
16817	Hensarlings Auto Service	GAS & Oil-Mini-Bus	26.15	
16821	H. L. Jackson, Gulf Dist.	Gas-Sheriff	1,571.31	
16840	Hartgraphics, Inc.	Forms-J. P. #1	49.47	
16832	J. B. Best & Co.	Clothing-Foster Child-P. Young	41.95	

4603.00

APPROVED THIS 13th day of March, 19781

COUNTY JUDGE [Signature]

CLAIMS CHECKED AND APPROVED
[Signature]
COUNTY AUDITOR

VOL. 6

pg. 361

COMMISSIONER'S COURT OF March 13, 19781 Page 1 of 1

CLAIM REGISTER AND MINUTES OF ACCOUNTS ALLOWED, Capital Improvements FUND TYLER COUNTY, TEXAS

Claim Number	NAME OF CLAIMANT	NATURE OF CLAIM	Amount of Claim	Da Allo
16809	A-E Project Management Serv.	Elevator Consultation & Management re	\$ 194.25	

APPROVED THIS 13th day of March, 19781
Allen Brown
COUNTY JUDGE

CLAIMS CHECKED AND APPROVED
Ann Jordan
COUNTY AUDITOR

VOL. 6 Pg 362

COMMISSIONER'S COURT OF March 13, , 19781

Page 1 of 1

CLAIM REGISTER AND MINUTES OF ACCOUNTS ALLOWED, Fed. Rev. Shar. FUND TYLER COUNTY, TEXAS

Claim Number	NAME OF CLAIMANT	NATURE OF CLAIM	Amount of Claim	Date Allowed
1274-a	Birdwells Welding & Machine Shop	Repair to Jail Windows-Jail Const.	\$ 503.80	
1272-a	City of Woodville	Smoke Detectors-Jail Construction	41.85	
1270-a	Deep East Tex. Wrok. Comp.	March Premium-Solid waste	66.58	
1266-a	Holderman Building Center	Replace Glass-Jail Construction	12.00	
1268-a	Mahan Plumbing	Repairs to Jail-Jail Const.	434.30	
1271-a	NCR Corp.	Data Cartridge-Auditor Office	118.44	
1267-a	W.C. Royle	T-Bars-Data Processing System	26.40	
1276-a	Southwestern Bell	Probation Telephone (2mos)	108.62	
1273-a	Sargent-Sowell Inc.	Smoke Ejector-325.06-Jail Const.		
		Emergency Light & Exting.-486.62	811.68	
1269-a	Tex. Dept. of Correction	Mattresses, Pillows-Jail Const.	433.80	
1275-a	Woodville Auto Parts	Pct. II-Repairs to Equip.	2,498.81	
		<i>Tot.</i>	<i>5,056.28</i>	

APPROVED THIS 13th day of March, 19781
Allen Brooks
 COUNTY JUDGE

CLAIMS CHECKED AND APPROVED
Ann Jondren
 COUNTY AUDITOR

002.6

Pg. 363

COMMISSIONER'S COURT OF March 13, . 197 81

Page 1 of 1

CLAIM REGISTER AND MINUTES OF ACCOUNTS ALLOWED, Road & Bridge IV FUND TYLER COUNTY, TEXAS

Claim Number	NAME OF CLAIMANT	NATURE OF CLAIM	Amount of Claim	D All
16892	Geo. P. Bane Inc.	Graphite	\$ 59.40	
16897	Fogle Equip. Co.	Parts	36.93	
16893	Freemans Contrete	Culverts	140.40	
16898	J.E. Gardner OI. Co.	Fuel	1,942.35	
16896	Gulf States	Utilities-Co. Barn	24.91	
16895	Gulf Welding Supply Co.	Oxygen	7.20	
16869	McInnis Hardware	Misc. Supplies	36.15	
16894	Woodville Auto Parts	Repairs to Equip.	372.03	
16812	Deep East. Tex. Work. Comp.	March Perm.	260.78	
		<i>Tot.</i>	<i>2,880.15</i>	

APPROVED THIS 13th day of March, 197 81

Robert Brown
COUNTY JUDGE

CLAIMS CHECKED AND APPROVED

Annie London
COUNTY AUDITOR

004.6 Pg. 364

COMMISSIONER'S COURT OF March 13, , 19781

Page 1 of 1

CLAIM REGISTER AND MINUTES OF ACCOUNTS ALLOWED, Road & Bridge III FUND TYLER COUNTY, TEXAS

Claim Number	NAME OF CLAIMANT	NATURE OF CLAIM	Amount of Claim	Date Allowed
16860	A&M Motor Co. Inc.	Parts	\$ 297.20	
16858	Geo. P. Bane, Inc.	Parts	34.81	
16859	J.E. Gardner Oil Co.	Fuel	1,671.78	
16849	Goodyear Service Stores	Tires & tubes	425.46	
16856	Jimmy's Auto Parts	Tools & Filters	641.81	
16861	Ogdon Exxon	Tire Repair-32.50, Gas-133.00	165.50	
16857	Woodville Auto Parts, Inc.	Parts	27.88	
16812	Deep East Tex. Work. Comp.	March Prem.	203.85	
			<i>Tot. 3,468.29</i>	

APPROVED THIS 13th day of March , 197 81

Allen [Signature]
COUNTY JUDGE

CLAIMS CHECKED AND APPROVED

Ann [Signature]
COUNTY AUDITOR

004.6

Pg 365

COMMISSIONER'S COURT OF March 13, 19781

Page 1 of 1

CLAIM REGISTER AND MINUTES OF ACCOUNTS ALLOWED, Road & Bridge II FUND TYLER COUNTY, TEXAS

Claim Number	NAME OF CLAIMANT	NATURE OF CLAIM	Amount of Claim	Da Allc
16889	Allen Machinery Co. Inc.	Hyd. Oil	\$ 41.80	
16867	Birdwells Welding & Mach. Shop.	Repairs to Winch Bed	102.00	
16886	Chester Water Supply Corp.	Utilities-Co. Barn	7.50	
16885	Geo. P. Bane, Inc.	Graphite	59.40	
16888	Gulf Welding Supply Co.	Oxygen	7.20	
16891	J.E. Gardner Oil Co.	Fuel	1,498.80	
16890	Hensarling's Auto Service	Tire Repairs	16.00	
16887	Sam Houston Elec.	Utilities-Co. Barn	4.38	
16812	Deep East Tex. Wrok. Comp.	March Prem.	172.36	
		Tot.	1909.44	

APPROVED THIS 13th day of March, 19781

Allen
COUNTY JUDGE

CLAIMS CHECKED AND APPROVED

Ann Fordren
COUNTY AUDITOR

VOL. 6 Pg. 366

COMMISSIONER'S COURT OF March 13, 19781 Page 1 of 1
 CLAIM REGISTER AND MINUTES OF ACCOUNTS ALLOWED, Road & Bridge I FUND TYLER COUNTY, TEXAS

Claim Number	NAME OF CLAIMANT	NATURE OF CLAIM	Amount of Claim	Da Allo
16864	Geo. P. Bane, Inc.	Graphite	\$ 67.65	
16882	Conoco, Inc.	Gas	71.05	
16903	Durham Elec. Co.	Repairs to Equip.	188.30	
16880	Freeman's Concrete	Culverts	80.76	
16883	J.E. Gardner Oil Co.	Fuel	1,709.33	
16877	Goodyear Service Stores	Tires, Tubes, Balance	375.10	
16879	Gulf States	Utilities-Co. Barn	29.42	
16878	Holderman's Bldg. Center	Street Broom	11.15	
16884	Seneca Water Supply	Utilities-Co. Barn	6.00	
16881	Woodville Auto Parts, Inc.	Repairs to Equip.	597.99	
16812	Deep East Tex. Wrok. Comp.	March Prem.	141.00	
		<i>Tot.</i>	<i>3,277.75</i>	

APPROVED THIS 13th day of March, 19781
 COUNTY JUDGE *Allen Branch*

CLAIMS CHECKED AND APPROVED
Ann Jondrew
 COUNTY AUDITOR

VOL. 6 Pg. 367

COMMISSIONER'S COURT OF March, 1981

Page 3 of 3

CLAIM REGISTER AND MINUTES OF ACCOUNTS ALLOWED, General FUND TYLER COUNTY, TEXAS

Claim Number	NAME OF CLAIMANT	NATURE OF CLAIM	Amount of Claim	D All
16811	Sullivans Hardware	Repairs to Courthouse-64.40 Locks-Sheriff 7.98	\$ 72.38	
16828	Sargent-Sowell, Inc.	Signs for Vehicles-Sheriff Dept.	64.55	
16839	Stafford Lowdon	Supplies-Co. Clerk 8.17, Dist. Clerk 82.08, JP #4 51.37	154.69	
16848	Sullivans	Janitors Supplies	54.28	
16850	Shepherds Linen Supply	Janitors Uniforms	32.00	
16835	Texas State Directory	2 Directories-Co. Judge	33.00	
16868	Tyler County Hospital	Medical Exp. for Prisoners-Sher.	20.00	
16824	Texaco, Inc.	Gas-Sheriff	79.13	
16826	The Phelan Co.	Food for Prisoners	47.63	
16829	Tyler Uniform Co.	Uniforms-Sheriff Dept.	440.49	
16855	Truett F. Pritchard & Assoc., Inc.	1/2 pmt- Valuation Services	2,000.00	
16875	Texas Surplus Property Agency	Co. Clerk 22.00 File Cabinet- Tax Off. 22.00	44.00	
16816	UniRoyal, Inc.	Tires - Sheriff	160.16	
16854	Western Data Services, Inc.	Tax Roll & Voter Regist. 3,097.51 Equip. Lease 366.00	3,463.51	
16844	Walraven	Co. Clerk-Crim. Docket Leaves	28.32	
16834	Wal-Mart Stores, Inc.	D. Atty. Office Supplies 20.62 Trash Cans-Janitors 53.28	73.90	
16852	Xerox Corp.	Dist. Clerk-Copy Machine	250.00	
16873	Xerox Corporation	Lease on Equip.-Co. Clerk	757.05	
16847	Zep Mfg. Co.	Cleaner-Janitors Supplies	39.20	
16812	Deep East Texas Workers Comp.	March Workers Corp. Prem.	361.62	
16827	Office Supply	Office Supplies-Co. Auditor	5.51	

8,181.92

APPROVED THIS 13th day of March, 1981

Allen Branch
COUNTY JUDGE

CLAIMS CHECKED AND APPROVED
Ann Jordan
COUNTY AUDITOR

002.6 Pg. 368

COMMISSIONER'S COURT OF March, 1978

Page 2 of 3

CLAIM REGISTER AND MINUTES OF ACCOUNTS ALLOWED, General FUND TYLER COUNTY, TEXAS

Claim Number	NAME OF CLAIMANT	NATURE OF CLAIM	Amount of Claim	A
16843	Jarrots Pharmacy	Film-Sheriff Dept.	\$ 5.25	
16866	Jimmy's Auto Parts	Floor Mats-Sheriff	80.55	
16814	Kirby, Glen L.	Court Appt'd Atty.-Cuzik&Logan	200.00	
16823	Knapp Ford Sales	Gas Cap-Sheriff	2.40	
16842	Lufkin Typewriter	Co. Clerk & Ribbons & Corr.-Auditor	79.00	
16874	Monroe	Service Contract-Co. Treasurer	57.00	
16820	Mobil Oil Credit Corp.	Gas-Sheriff	49.25	
16833	Mary Lee School	G. Broaddus 1,446. Foster Child Care-C. Mashtere1,426.	2,872.00	
16845	Monroe	Service Contracts	664.00	
16901	Mahan Plumbing	Repairs to Plumbing	18.42	
16853	Mann, Robert H., Atty.	Court appt'd Atty. re J.M. Brown	100.00	
16815	Power, S. D.	Court Reporter Mileage	154.70	
16862	Phillips Heating & Air Cond.	Repairs to Run Way Lights-Airport	29.50	
16900	Rogers Office Supply	Sheriff 110.15, Co. Clerk 134.40, JP #1 5.14, DPS 7.80, Exten.16.55 Co. Atty. 24.80, Treas. 11.30, Dist. Clerk 25.15, Tax Off. 22.30 Auditor 12.60, Req. Books 441.50	811.69	
16863	Sam Houston Elec.	Utilities - Airport	126.89	
16899	Southwestern Bell Telephone	JP #4 31.38, Sheriff 340.19, JP #2 15.77, Veterans 15.46, Auditor 44.70, Ageing 23.94, Houseing 15.46, Exten. 115.03, Comm. off. 47.25, JP #1 67.24, DPS 125.56, DA 50.13, Tax off. 92.31, D. Jud. 36.19, D. Clerk, 43.26, Treas. 64.19, C. Clerk, 33.82, Airport 56.06, Co. Judge 85.21	1,303.15	
			6553.80	

APPROVED THIS 13th day of March, 1978!

COUNTY JUDGE

Allen Burrows

CLAIMS CHECKED AND APPROVE

COUNTY AUDITOR

Ann Jordan

Memo
3/13/81

Vol. 6

pg. 369

TYLER COUNTY, TEXAS
GENERAL FUND DISBURSEMENTS
1981 BUDGET AMENDMENT
March 13, 1981

	1981 Budget	Amended To	Increase (Decrease)
<u>DISTRICT ATTORNEY:</u>			
<u>Personal Services:</u>			
Salary, DA Secretary (Bi-Co.)	\$ 1,491.00	\$ 1,491.00	\$.....
Salary, Tyler County Sec.	643.00	643.00
Salary, Asst. Dist. Atty.	2,456.00	1,466.00	(990.00)
Salary, Criminal Investigator	2,772.00	2,772.00
Social Security	920.00	920.00
Retirement	1,178.00	1,178.00
Hospitalization	660.00	660.00
Total Personal Serv.	<u>10,120.00</u>	<u>9,130.00</u>	<u>(990.00)</u>
<u>Operating Expenditures:</u>			
Office Supplies	700.00	700.00
Miscellaneous	100.00	100.00
Telephone	225.00	225.00
Criminal Inv. Travel	990.00	990.00
Total Operating	<u>1,025.00</u>	<u>2,015.00</u>	<u>990.00</u>
TOTAL DISTRICT ATTORNEY:	\$11,145.00	\$11,145.00	\$.....

Note: The above "Personal Services" are funded for a six month period only. \$990.00 was deducted from the Asst. Dist. Attorney salary. This salary slot has not been filled from the beginning of the fiscal year.



TILT

12, 15, 17 AND 20 TONS

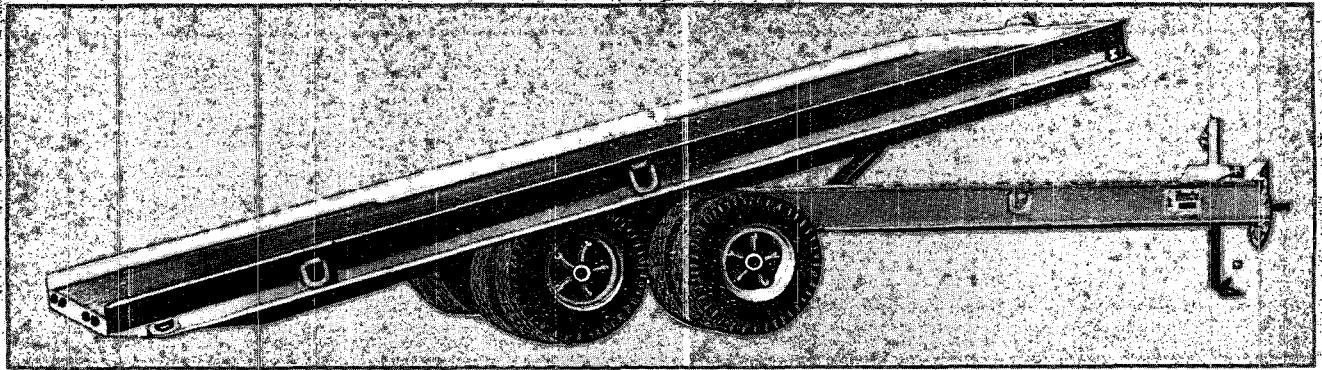

DBT-DRAW BAR TILT

			TIRE RATINGS	
12-DBT	A — Air Brakes or	Tires . . . 7:50 x 15 —	Load Range — F	At 40 MPH
	E — Electric Brakes	Rims . . . 6:50 x 15		
15-DBT	A — Air Brakes or	Tires . . . 8:25 x 15 —	Load Range — F	At 30 MPH
	E — Electric Brakes	Rims . . . 6:50 x 15		
17-DBT	A — Air Brakes or	Tires . . . 8:25 x 15 —	Load Range — G	At 30 MPH
	E — Electric Brakes	Rims . . . 6:50 x 15		
20-DBT	A — Air Brakes or	Tires . . . 10:00 x 15 —	Load Range — G	At 40 MPH
	E — Electric Brakes	Rims . . . 7:50 x 15		

Standard Equipment

DECK — 2" Net Oak . . . 8' Wide x 20' Long

BRAKES — Air . . . 12 1/4" x 7 1/2"

Electric . . . 12 1/4" x 5 1/2"

WHEELS — 15" Cast Spoke with Oil Seals

HITCH — 3" Adjustable Eye Hitch

RINGS — 6 Heavy Duty Lashing Rings

AXLE — 5" Round — 20,000 lb. Capacity

CYLINDERS... 12 & 15-Ton..One 3" H/D Hydraulic
17 & 20-Ton..Two 3" H/D Hydraulic

D.O.T. & I.C.C. REQUIREMENTS

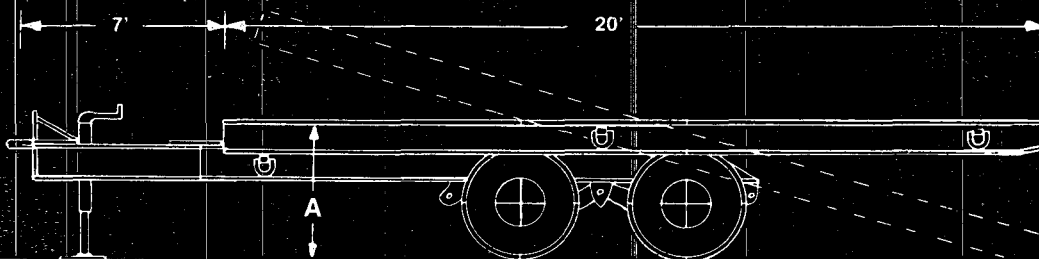

MODELS	12	15	17	20
Approx. Deck Height	35"	36"	37"	39"
Approx. Shipping Wgt.	7100#	7200#	7325#	7700#

DEGREE OF TILT	
12 Ton	15°
15 Ton	15°
17 Ton	17°
20 Ton	19°



LOWBED FEATURES

Three steel bars are welded in the gooseneck. These stiffeners prevent distortion of kin pin plate. Adds extra strength to king pin.

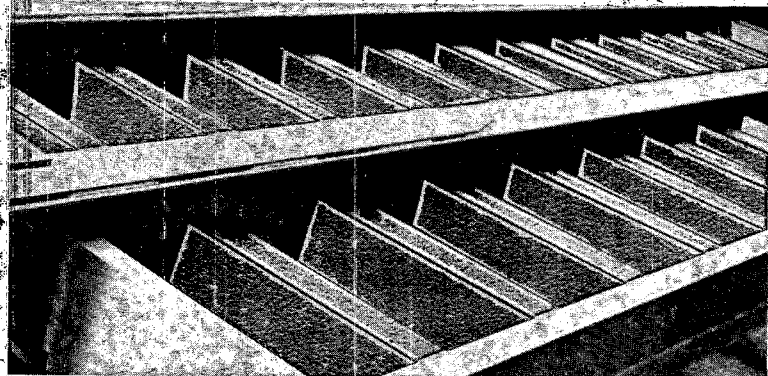
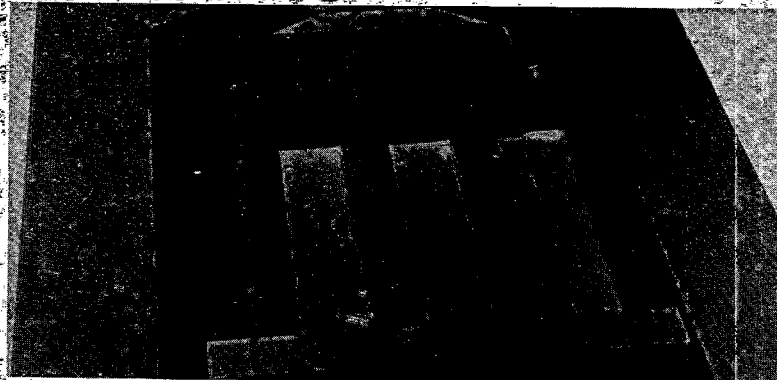

One Piece Cross Members — Pierced. Main Beams . . . Much stronger . . . Quality engineered.

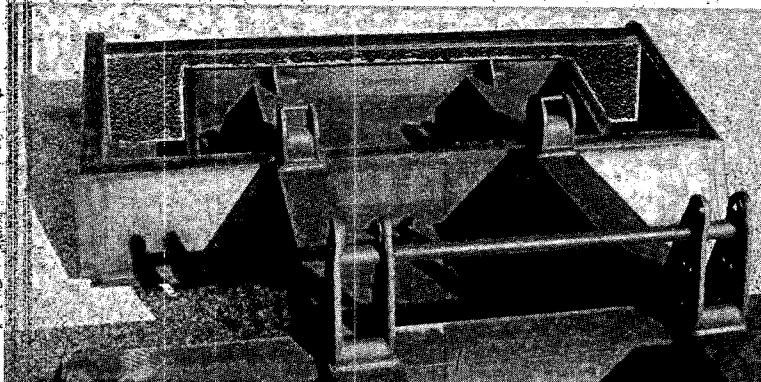

This underside view of our beaver Tail shows how we protect wires and tail lights with steel angles and steel plate.

One Piece Steel Cover Plate adds strength to rear end . . . maintains alignment . . . less side walk or anti-rack.

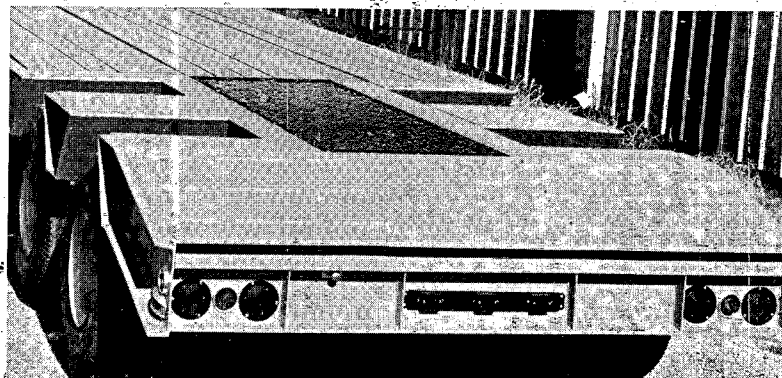

NOTICE OF TIME AND PLACE OF MEETING

COMMISSIONERS COURT
TYLER COUNTY, TEXAS

THIS NOTICE POSTED IN ACCORDANCE WITH V. A. T. S. - ART. 6252-17

NOTICE is hereby given that Commissioners Court will hold it's
Special meeting on FRIDAY, MARCH 13 1981 at 10:00 A.M.
in the Commissioners Courtroom, First Floor, Tyler County Courthouse.

A G E N D A

1. APPROVE PAYING BILLS FROM AUDITORS OFFICE.
2. DON COLE.
3. JOE WEEKS.
4. OPEN BIDS ON USED CAR FROM SHERIFFS OFFICE. (Tabled from March 9th.)
5. OPEN BIDS ON CHAIN LINK FENCE. (PCT.III). (Tabled from March 9th.)
6. OPEN BIDS ON TILT TRAILER. (PCT.III). (Tabled from March 9th.)
7. JOHN SPANHANKS ON EXTERMINATING THE COURTHOUSE.
8. JOE SMITH ON 6 MAN JURY BOX FOR COUNTY COURT.
9. CONSIDER ASSUMING RESPONSIBILITY OF DRUG DOG.
10. BUDGET REVISION FOR DISTRICT ATTORNEYS OFFICE.
11. RESOLUTION CONCERNING JUVENILE JUDGES PAY.

Allen Sturrock, County Judge
Tyler County, Texas

NO. _____ TIME: 8:30 ^{AM}/_{PM}

MAR 10 1981

GRACE BOSTICK, COUNTY CLERK
TYLER COUNTY, TEXAS

BY: Janet Gregory
Janet Gregory